

IVC1 series programmable logic controllers

Brief introduction

INVT Automatic Control Technology CO., LTD, a subsidiary company invested by Shenzhen INVT Electric Co., LTD, is established in Aug, 2011. As an integrated high-tech enterprise, it specializes in the R&D, production, sales and service on industrial automation, and has many experienced technicians who have been working in the field for many years. Rely on the base of powerful technical strength, advanced production equipment and improved service system, we strive to be the leading international supplier of industrial control and automation through an unyielding commitment of innovation, diligent research and development.

Shenzhen INVT Electric Co., Ltd is a national high-technology cooperation which has invested 9 subsidiary companies involved in electrical drive, industrial automation, new energy, rail transport traction, mining explosion-proof, energy management and building intelligence, ect. With the total population of 1100, up to 30 domestic national and international offices, the company is listed in 2011(stock code: 002334) and set feet on more than 60 nationals and regions.

Corporate concept

- Management conception: union, pragmatism, diligence, and aggressiveness
- ◆ Company vision: to be a leading and respectable supplier of electrical drive, industrial control products in the world market.
 - ◆ Company mission: focus on desirable and competitive products and services
 - ◆ Core value: Solidarity, honest, struggle and innovation



INVT Automatic Control Technology CO., LTD
Headquarter: No.4 Building, Gaofa Scientific Industrial Park, Longjing, Nanshan District, Shenzhen, China
Production base: Building A, Juyuan Industrial Park A area, Tanwei county, Fuyong town, Baoan District, Shenzhen, China

Tel: 86-755-86553062
Fax: 86-755-86553030
National service hotline: 400-700-9997
Website: www.invt-control.com



Automation Solutions

IVC1 series PLC



VT series HMI



Servo drive/ motor



The inverter



UPS power supply



IVC1 series PLC

IVC1 series PLC is a mini high-performance PLC with small structure and powerful functions. It can be widely used in the mechanical manufacture industries such as textile fiber, machine tools, cables, foods and drinks, packages, plastics and steels, buildings, air conditioners, elevators and printing.

- > Small size, high configuration, high-capacity and fast speed
- > Strong positioning and high-speed processing capability
- > Strong communication
- > Powerful programmable software



VT series HMI

VT series HMI is easy for the human-machine interface in industry automation with the advantages of various displaying modes, high capacity, flexible configuration and simple operation.

- > Various picture controls
- > Multiple language displaying
- > Support multiple communication connections and sub-connection
- > Support up to 16 data formula
- > A variety of file operations, and easy access to data application



Product Overview >>

Main module



16-point main modules

IVC1-1006M □ □
 Power supply voltage: 100-240VAC/24VDC
 10-point input, 6-point output
 Relay output, transistor output
 Up to 7 modules extension



30-point main modules

IVC1-1614M □ □
 Power supply voltage: 100-240VAC/24VDC
 16-point input, 14-point output
 Relay output, transistor output
 Up to 7 modules extension



60-point main modules

IVC1-3624M □ □
 Power supply voltage: 100-240VAC/24VDC
 36-point input, 24-point output
 Relay output, transistor output
 Up to 7 modules extension



24-point main modules

IVC1-1410M □ □
 Power supply voltage: 100-240VAC/24VDC
 14-point input, 10-point output
 Relay output, transistor output
 Up to 7 modules extension



40-point main modules

IVC1-2416M □ □
 Power supply voltage: 100-240VAC/24VDC
 24-point input, 16-point output
 Relay output, transistor output
 Up to 7 modules extension



The main module of integrated analog

IVC1-1614MA □ □
 Power supply voltage: 100-240VAC/24VDC
 Digital I/O
 16-point input, 14-point output
 Analog I/O
 2 Inputs, 1 output
 Relay output, transistor output
 Up to 7 modules extension

I / O extension module

- > 8-point input: IVC1-0800ENN
8-point input
- > 16-point output: IVC1-0016EN □
Transistor output, relay output
- > 16-point Input/Output IVC1-0808EN □
8-point input, 8-point output
Transistor output, relay output
- > 8-point output: IVC1-0008EN □
Transistor output, relay output



Special modules

- > Analog Input: IVC1-□AD
2 analog inputs, 4 analog inputs
- > Analog Output: IVC1-□DA
2 analog outputs, 4 analog outputs
- > Analog input and output: IVC1-5AM
4 analog inputs and 1 analog output
- > The thermocouple module: IVC1-□TC
2 inputs, 4 inputs
- > The thermal resistor module: IVC1-□PT
2 inputs, 4 inputs



Communication Adapter

- > Ethernet adapter: IVCS-EPM
 Ethernet Interface: RJ-45
 Ethernet communication protocols: ICMP, ARP, IP, TCP, UDP, and DHCP, MODBUS, TCP, remote programming interface protocol
 Serial interface: DB9-M-R
 Serial communication protocol: MODBUS, TCP, remote programming interface protocol



Product Overview >>

Main module

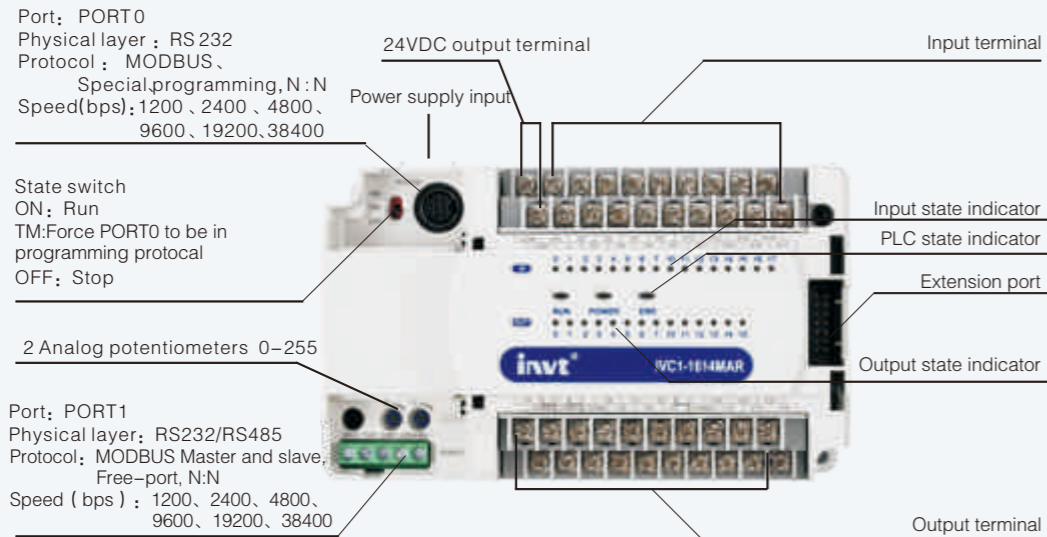

I/O extension module

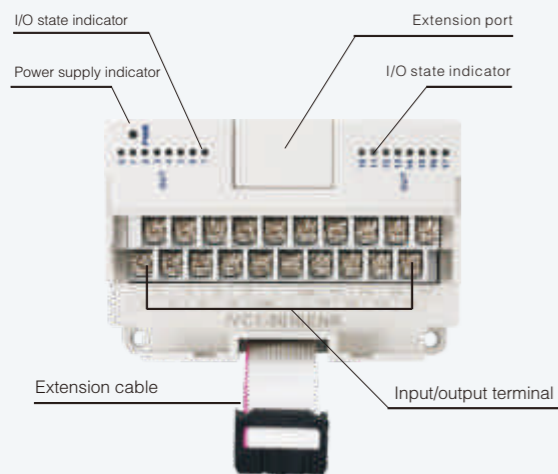

Special modules

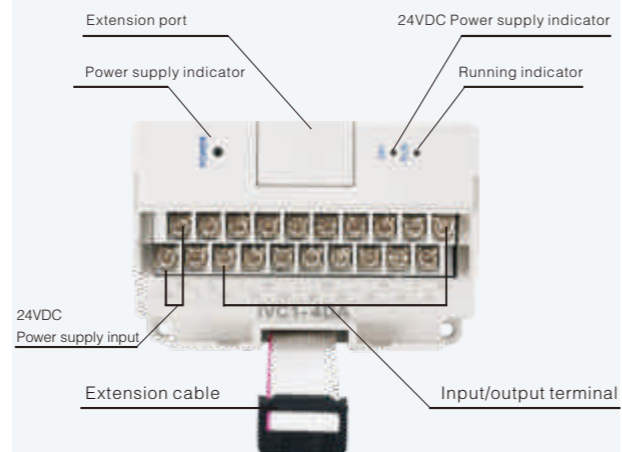

Product Configuration >>

Integrated analog input and output

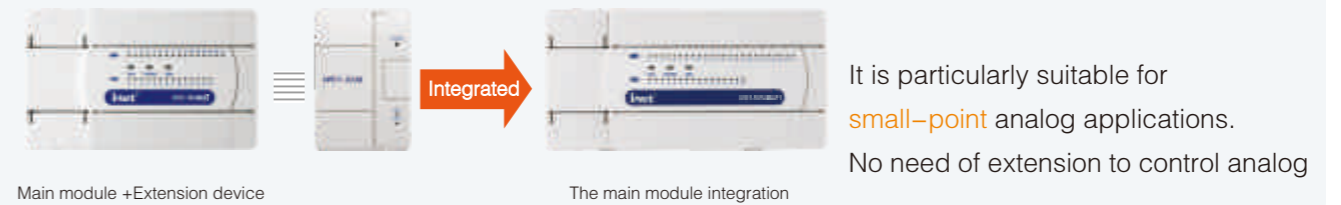

Integrated **2-point** analog input and **1-point** analog output

Extension capability



up to **128** extended I / O points

Program capacity



Program capacity can be 16K steps without any extension and additional costs

Processing speed

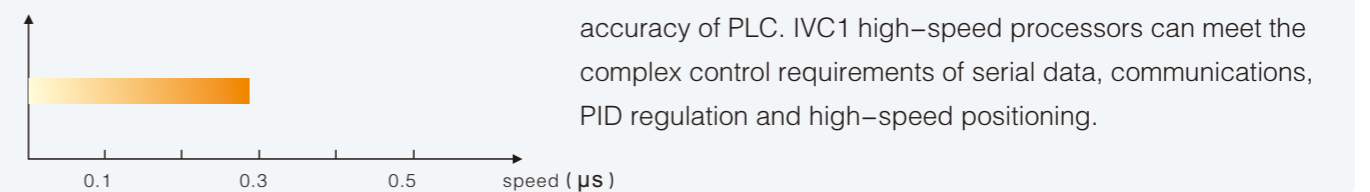

Basic instruction processing speed is up to **0.3μs**, high-speed scanning is also available

Product Configuration >>

Positioning and high-speed pulse processing

- > Built-in high-speed counter, support three counting modes
- > The main module (transistor) provides two independent pulse output

PTO: 50%

Pulse

Frequency

PWM:

cycle

Pulse

Y0

Y1

100kHz

100kHz

X0-X5

- > High-speed counting: 32-bit
- Single-phase counting: 6(2.50KHz, 4.10KHz)
- Dual-phase counting: 291.30KHz, 1.5KHz
- > Frequency detection: 6, Max. 10KHz
- > Pulse capture: 8
- X0~X1: 20ms
- X2~X7: 100ms

The CPU scanning time does not impact the high-speed processing.

High-speed counting

- > 6 single-phase counting: 2-50KHz; 4-10KHz
- > 2 duplex counting: 1-30KHz, 1-5KHz



Pulse output

- > 2 independent 100KHz high-speed pulse output
- > Support the pulse train output (PTO) and pulse width modulation (PWM) mode High-speed counting

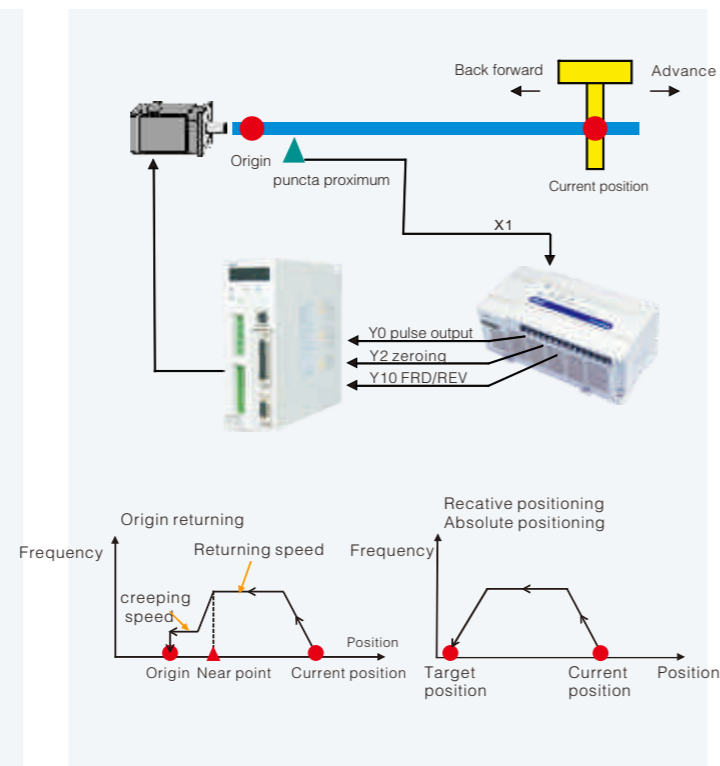

Communication >>

Device connection

- > Provide 2 communication ports and have various internal communication protocols to support a variety of networking.



N:N network

- > Network between multiple PLC can make the access to specified M and D component dates available. It is particularly suitable for the interlock between the distributed related equipment in control system. There is no need of programming if applies N: N protocol.

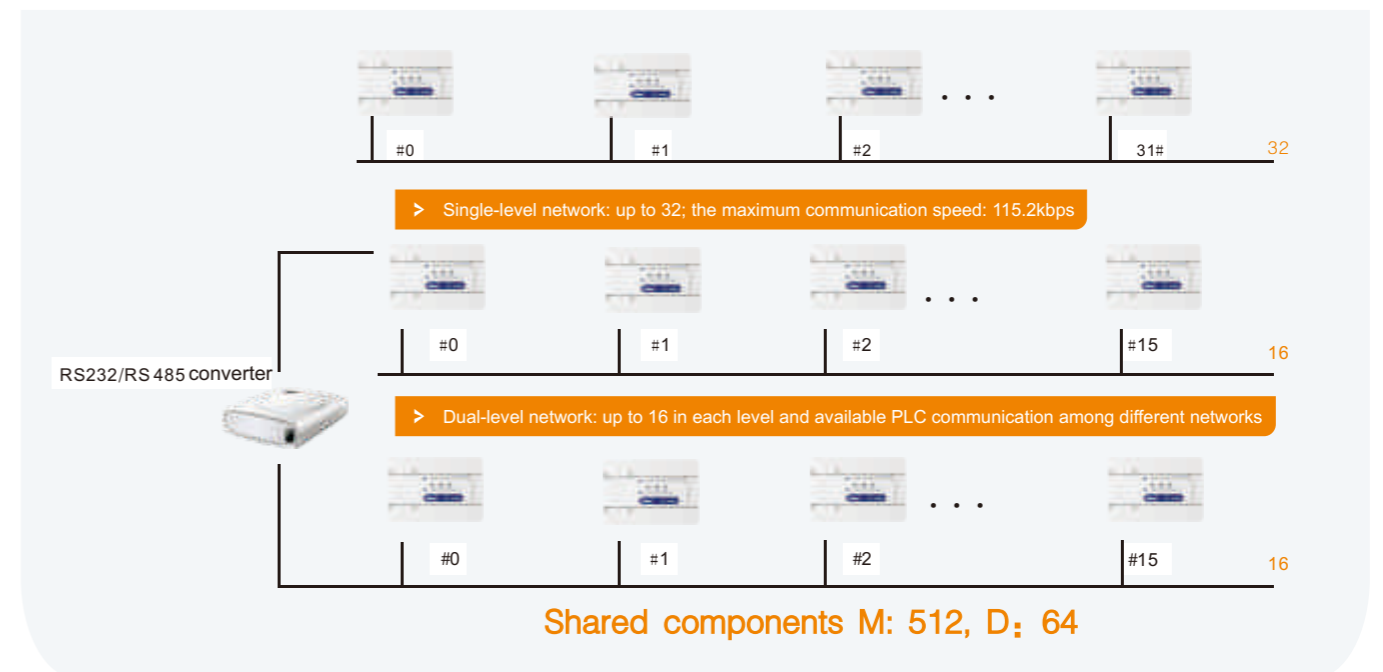

Programming Software

- > Support multiple programming languages
- > Support the import and export of subroutines and global variables
- > Support online debugging
- > Occupying less system resources, fast response

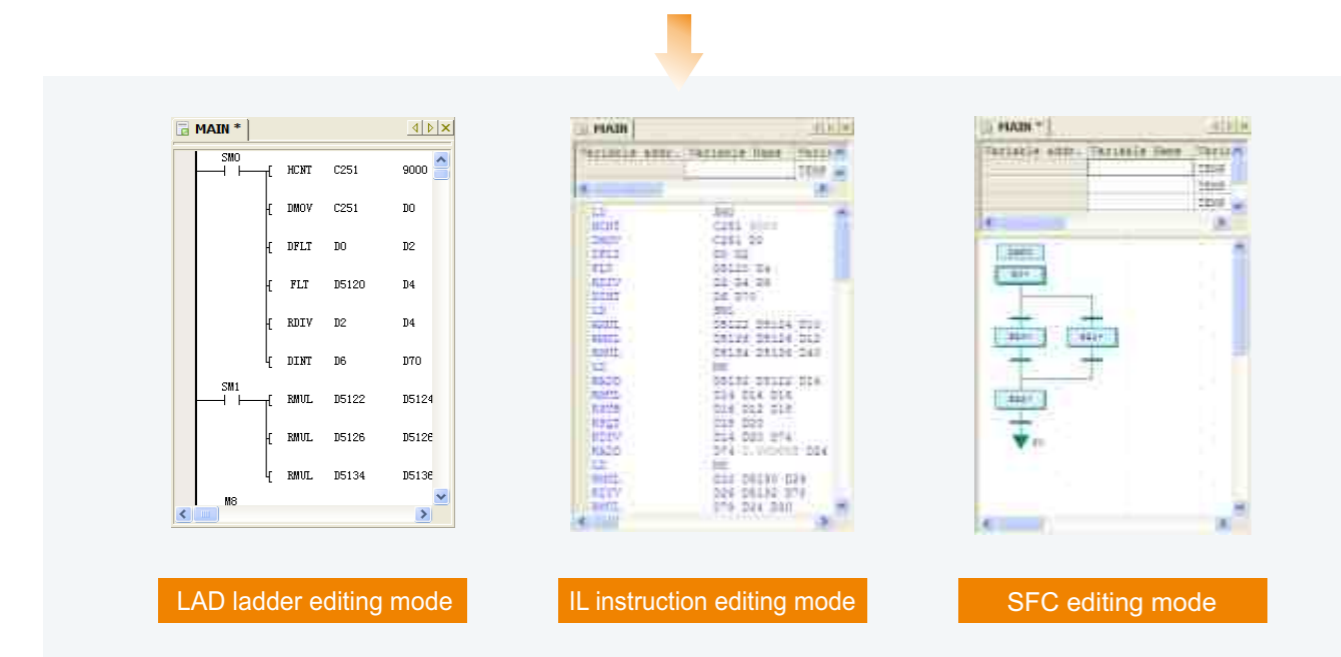
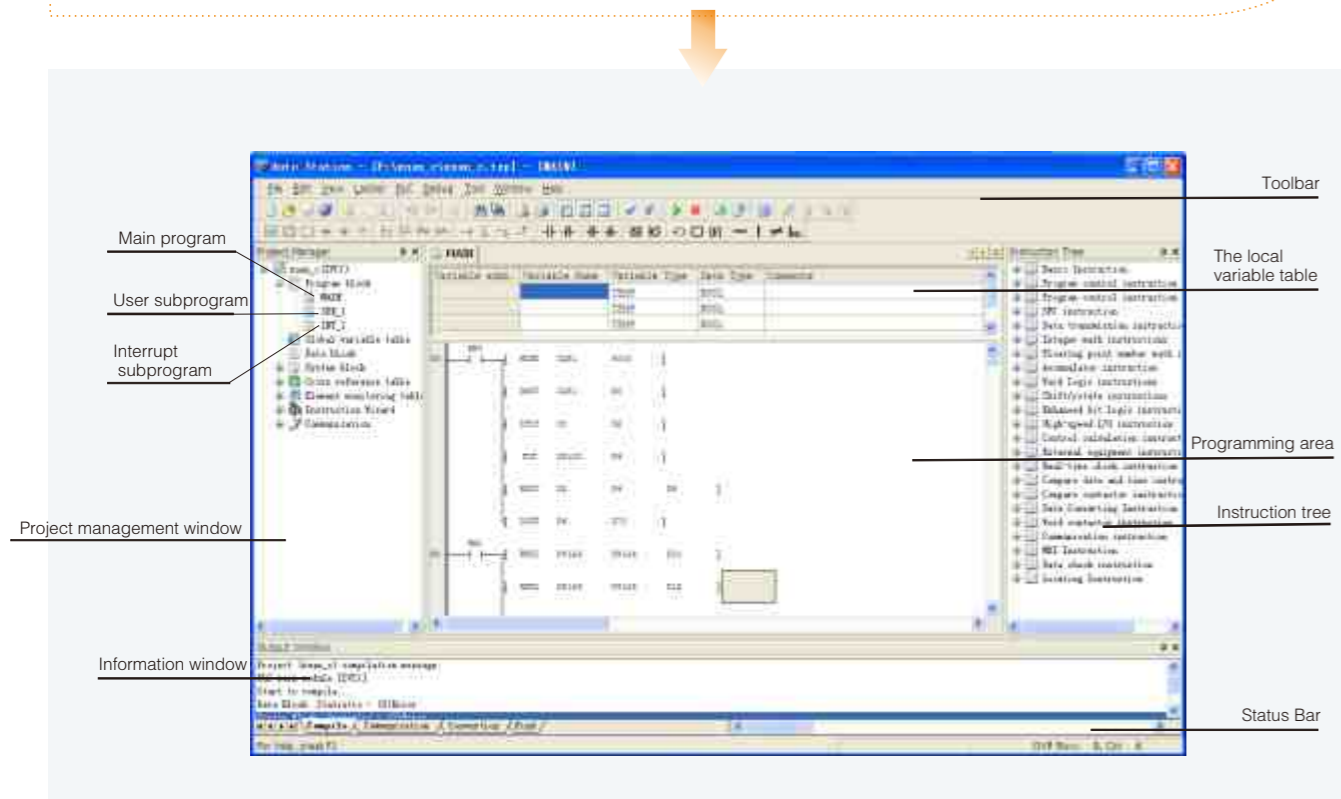

Special Function Configuration

- > Provide special function configuration window in system block for programming instructions without reference and complex settings.

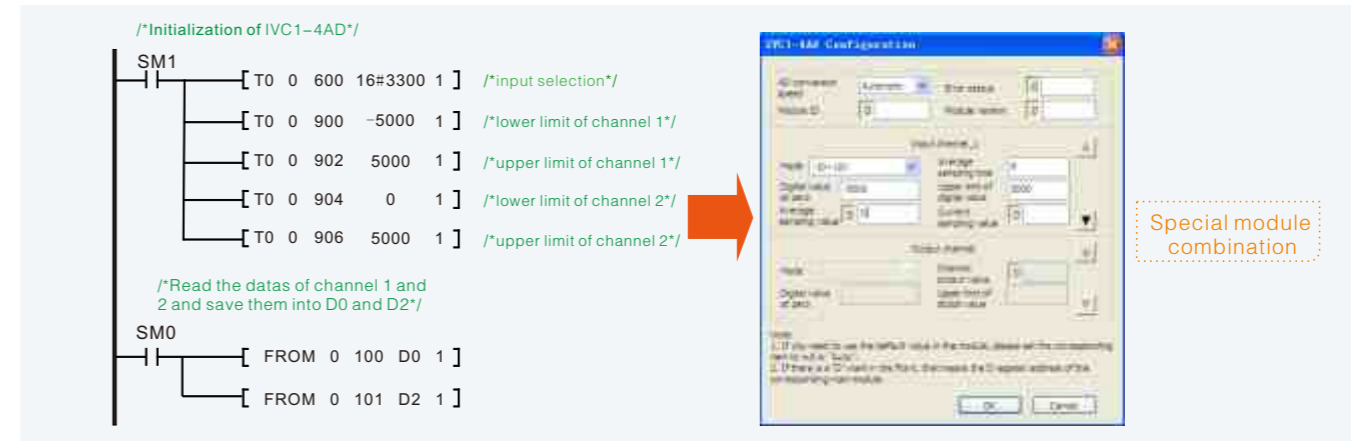

Convenient communication instruction

- > No need of complex program and access the communication control to the inverter with one instruction

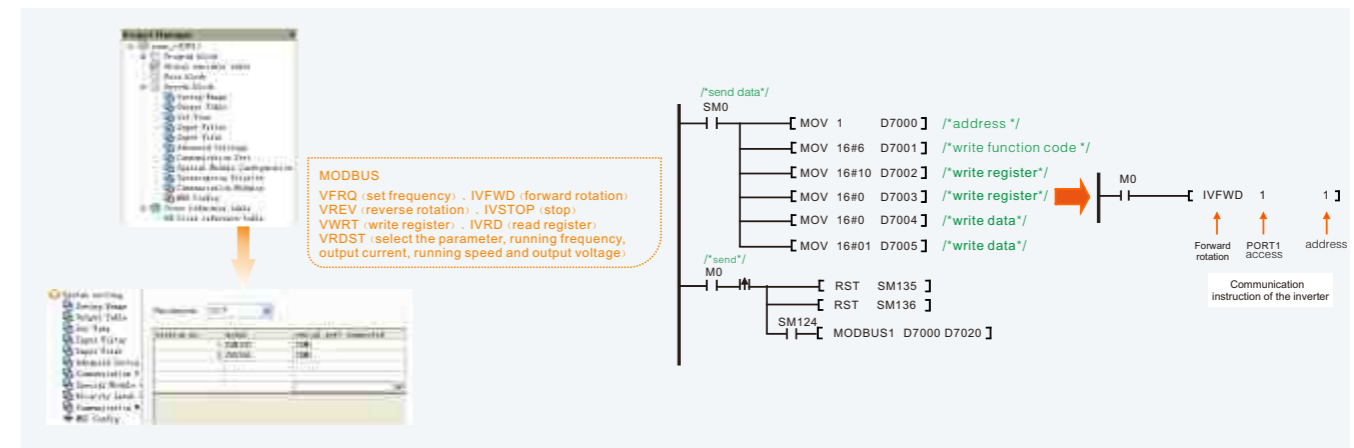

Command wizard

- > Use the command wizard to complete the preparation of complex instructions

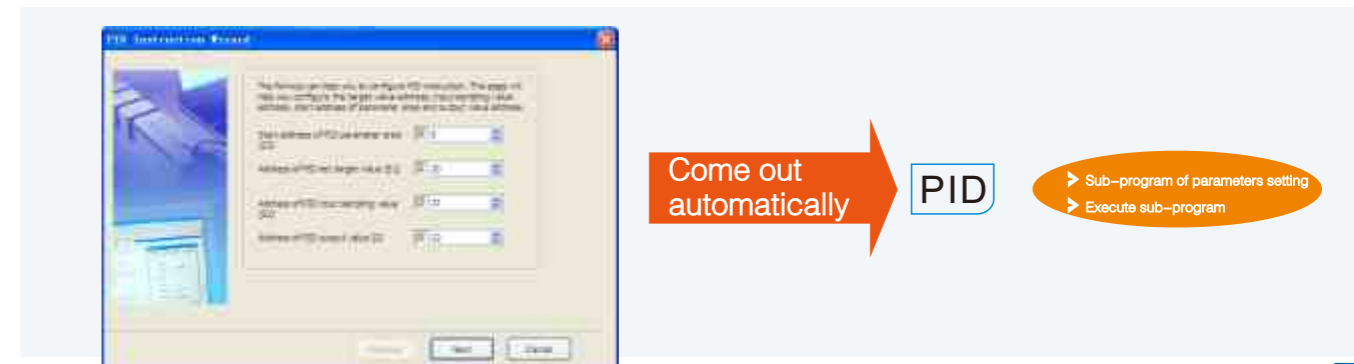

Specifications and technical datas

General specification of the main module

Project	Specification
Rated voltage	100 ~ 240VAC/24VDC
Allowed voltage range	85 ~ 264VAC/19 ~ 30VDC
Application temperature	-5~55°C
Storage temperature	-40~70°C
Application humidity	10~95%(no condensation)
Storage humidity	10~95%(no condensation)
Air pressure	80~106kPa
Withstand voltage	2830VAC or equivalent DC voltage 1 minute, no breakdown or flashover; leakage current ≤ 5mA
Insulation resistor	≥ 5x10 ⁹ Ω (500VDC)
Shock	Displacement: 3.5mm, acceleration speed: 10M/s ² , frequency range: 5-150Hz, 10 times of scanning in the direction of XYZ
Impact	Half-sine, Pulse width: 6ms, acceleration speed: 180 M/S ²
Contamination	2
Protection degree	IP 20
Certification	Pass the CE certification according to the standards of IEC61131-2 and UL508

Electrical features of main module input

Project	High-speed input X0-X7	Common input terminal	
Input terminal	Input type	All input need to keep the same	
	Input impedance	3.3k~4.3k	
	Output current	6.5mA TYP	5.3mA TYP
	ON voltage/current	DC18V Min/4.5mA min	DC18V Min/3mA min
	OFF voltage/current	DC4V Max/1mA max	DC4V Max/1mA max
	Digital filter time	Only X0-X7 is adjustable in 0-64ms	
	Pulse capture	Pulse capture is only available in X0-X7	

Main performances of the main module

Project	Specification	
Execution mode	Cycle scan + pause mode	
Program mode	Instruction list, ladder diagram and sequence function diagram	
Instruction type	Basic instructions	32
	Application instructions	226
Execution time	Basic instructions	0.3 μs
	Application instructions	Several μs ~ hundreds of μs
Program capacity	16K step	
Max. extension	7 extension modules, including I/O extension module and special function module	
Input relay (X)	X0~X177, 128 points, Octal encoder	
Output relay (Y)	Y0~Y177, 128 points, Octal encoder	
Auxiliary relay (M)	M0 ~ M2047, 2048 points	
Local auxiliary relay (LM)	LM0 ~ LM63, 64 points	
Special auxiliary relay (SM)	SM0 ~ SM255, 256 points	
State relay (S)	S0 ~ S1023, 1024 points	
Timer (T)	256 points (T0 ~ T255)	100ms accuracy: T0~T209, 210 10ms accuracy: T210~T251, 42 1ms accuracy: T252~T255, 4
Counter (C)	256 points (C0 ~ C255)	16-bit incremental counting: C0~C199, 200 32-bit incremental/decremental counting: C200~C235, 36 3232-bit high speed counting: C236~C255, 20
Date register (D)	D0 ~ D7999, 8000 points	
Local date register (V)	V0 ~ V63, 64 points	
Indexed register (Z)	Z0 ~ Z15, 16 points	
Special data register (SD)	SD0 ~ SD255, 256 points	
Save function when power off	Save M, S, D, C components, bit element 320, word element 180	
Storage media	EEPROM+FLASH	
High-speed counter	Single phase: 6 groups, 2*50KHz+4*10KHz; Double phase: 2 groups, 1*30KHz+1*5KHz	
Pulse output	Y0, Y1, seperated 100kHz output	
Interrupt resource	External input interrupt	16 (X0~X7, 8 channels support rising edge and falling edge)
	High-speed counting interrupt	6
	Timing interrupt	3
	Communication interrupt	8
	Power interrupt	1
Analog potentiometer input	2 (0 ~ 255)	
Pulse capture	8 channels, X0~X1: 20 μs, X2-X7: 100 μs	
Digital filtering	X0-X7 provides digital filtering, filtering time(ms): 0, 8, 16, 32, 64, other hardwares filtering	
Communication port	2 channels (1 channel is RS-232, 1 channel is RS-232/RS-485 optional)	

Specifications and technical datas >>

Output electrical features of main module

Project	Relay output terminal	Transistor output port
External power supply	250VAC, below 30VDC	5 ~ 24VDC
Circuit insulation	Mechanical isolation of relay	Opto-isolation
Action instructions	Light on when relay output contact switch on	Light on when optocoupler is driven
Leakage current when switching off	/	Less than 0.1mA/30VDC
Mini. load	2mA/5VDC	5mA (5 ~ 24VDC)
Maximum output current	Resistor load	Y0, Y1: 0.3A/1-point; Other: 0.3A/1-point 0.8A/4-point 1.2A/6-point 1.6A/8-point Increase 0.1A for every 1 point when exceed 8 points
	Inductive load	220VAC, 80VA
	Lgihl load	220VAC, 100W
Response time	ON→OFF	Max. 20ms
	OFF→ON	Max. 20ms
Output common terminal	Y0-COM0; Y1-COM1; 1 common terminal is up to 8 terminals after Y2; the common terminal is isolated from each other	
Fuse protection	Null	

Specification of analog input module

Project	Specification	
Input channel	4, 2	
Conversion accuracy	12bits	
Power supply	Analog circuit	24V DC -15%/20%, Maximum allowable ripple voltage 5% input current 50mA (from the external power supply of the main unit)
	Digital circuit	5V DC, 70mA (from the internal power supply of the main unit)
Occupied I/O point	Null	
Conversion speed	15ms/channel (common speed), 6ms/channel (fastest)	
Analog input range	Voltage input	-10~10V DC, -5~5V DC (input impedance is 1M Ω), select the input range by setting BFM
	Current input	-20~+20mA (input impedance is 250 Ω)
Resolution	Voltage input	5mV
	Current input	10 μ A
Accuracy	\pm 1%	
Isolation	The analog circuit is isolated from the digital circuit with optocoupler. The analog circuit is isolated from the external power supply with DC/DC. No need to isolate the analog channels.	

Specification of analog output module

Project	Specification	
Output channel	4, 2	
Conversion accuracy	12bits	
Power supply	Analog circuit	24V DC -15%/20%, Maximum allowable ripple voltage 5% input current 120mA (from the external power supply of the main unit)
	Digital circuit	5V DC 72mA (from the external power supply of the main unit)
Occupied I/O point	Null	
Conversion speed	2ms/channel (the channels change will not change the conversion speed)	
Analog output range	Voltage output	-10~10V DC (external load impedance \geq 2K Ω)
	Current output	0-20mA, 4-20mA (external load impedance \leq 520 Ω)
Digital input	Default setting: -2000~2000; allowable setting: -10000~10000	
Resolution	Voltage output	5mV (10V/2000)
	Current output	10 μ A (20mA/2000)
Accuracy	\pm 1%	
Isolation	The analog circuit is isolated from the digital circuit with optocoupler. The analog circuit is isolated from the external power supply with DC/DC. No need to isolate the analog channels.	

Specification of analog input/output module

Project	Specification	
Channel	Input	4
	Output	1
Conversion accuracy	12bits	
Power supply	Analog circuit	24V DC -15%/20%, Maximum allowable ripple voltage 5% input current 90mA (from the external power supply of the main unit)
	Digital circuit	5V DC 72mA (from the external power supply of the main unit)
Occupied I/O point	Null	
Conversion speed	AD Conversion speed	15ms/channel (common speed), 8ms/channel (high speed)
	DA Conversion speed	2ms/channel (fastest)
Analog input range	Voltage input	-10~10V DC, -5~5V DC (input impedance is 1M Ω), input signal frequency < 10Hz
	Current input	-20~+20mA (input impedance is 250 Ω)
Analog output range	Voltage output	-10~10V DC (external load impedance \geq 2K Ω)
	Current output	0~20mA, 4~20mA (external load impedance \leq 520 Ω)
Digital output/input	Default setting: -2000~2000; allowable setting: -10000~10000	
Resolution	Voltage input	5mV
	Current input	10 μ A
	Voltage output	5mV
	Current output	10 μ A
Accuracy	\pm 1%	
Isolation	The analog circuit is isolated from the digital circuit with optocoupler. The analog circuit is isolated from the external power supply with DC/DC. No need to isolate the analog channels.	

Adapter specifications

Project		Specification
Ethernet port	Interface	RJ-45
	Transmission	IEEE 802.3
	Transmission rate	10 Mbps
	Isolation protection	1.5KV Isolation
	Communication protocol	ICMP, ARP, IP, TCP, UDP, DHCP, MODBUS TCP, Remote programming interface protocol
Serial ports	Interface	DB9-M-R
	Transmission	RS232/RS485 (can not be used at the same time)
	Transmission rate	1200, 2400, 4800, 9600, 19200, 38400, 57600, 115200
	Communication protocol	MODBUS TCP, Remote programming interface protocol
	Operating Temperature	0 ~ 55 Degrees Celsius
Environment	Storage Temperature	-20 ~ 70 Degrees Celsius
Electric	Operating voltage	24VDC (-15% ~ +20%) , Maximum allowable ripple voltage 5%, 50mA

Specification of thermal resistor module

Project		Specification			
		Celsius (°C)		Fahrenheit (°F)	
Input channels		2, 4			
Power supply	Analog circuit	24V DC -15%/20%, Maximum allowable ripple voltage 5% · 55mA (from the external power supply of the main unit or external connection)			
	Digital circuit	5V DC 72mA(from the external power supply of the main unit or the source extension unit)			
Occupied I/O point		Null			
Input signal		Thermal resistor: Pt100, Cu100, Cu50			
Conversion speed		(15±2%) ms×used channels (no conversion for the unused channels)			
Rated temperature range	Pt100	-150°C ~ +600°C	Pt100	-238°F ~ +1112°F	
	Cu100	-30°C ~ +120°C	Cu100	-22°F ~ +248°F	
	Cu50	-30°C ~ +120°C	Cu50	-22°F ~ +248°F	
Digital output	12 bit A/D conversion, the temperature is stored through 16-bit binary complement				
	Pt100	-1500°C ~ +6000°C	Pt100	-2380 ~ +11120	
	Cu100	-300°C ~ +1200°C	Cu100	-220 ~ +2480	
	Cu50	-300°C ~ +1200°C	Cu50	-220 ~ +2480	
Mini. resolution	Pt100	0.2°C	Pt100	0.36°F	
	Cu100	0.2°C	Cu100	0.36°F	
	Cu50	0.2°C	Cu50	0.36°F	
Accuracy		Full scale ±1%			
Isolation		The analog circuit is isolated from the digital circuit with optocoupler. The analog circuit is isolated from the internal power supply of module input 24VDC. No need to isolate the analog channels.			

Specification of thermocouple module

Project		Specification				
		Celsius (°C)		Fahrenheit (°F)		
Input channels		2, 4				
Power supply	Analog circuit	24V DC -15%/20%, Maximum allowable ripple voltage 5%, 50mA(from the external power supply of the main unit or external connection)				
	Digital circuit	5V DC 72mA(from the external power supply of the main unit or the source extension unit)				
Occupied I/O point		Null				
Input signal		Thermocouple: type K, J, E, N, T, R, S				
Conversion speed		(240±2%) ms×used channels (no conversion for the unused channels)				
Rated temperature range	Type K	-100°C ~ +1200°C	Type K	-148°F ~ +2192°F		
	Type J	-100°C ~ +1000°C	Type J	-148°F ~ +1832°F		
	Type E	-100°C ~ +1000°C	Type E	-148°F ~ +1832°F		
	Type N	-100°C ~ +1200°C	Type N	-148°F ~ +2192°F		
	Type T	-200°C ~ +400°C	Type T	-328°F ~ +752°F		
	Type R	0°C ~ 1600°C	Type R	32°F ~ 2912°F		
	Type S	0°C ~ 1600°C	Type S	32°F ~ 2912°F		
	Digital output	12-bit A/D conversion, the temperature is stored through 16-bit binary complement				
Type K		-1000 ~ +12000	Type K	-1480 ~ +21920		
Type J		-1000 ~ +10000	Type J	-1480 ~ +18320		
Type E		-1000 ~ +10000	Type E	-1480 ~ +18320		
Type N		-1000 ~ +12000	Type N	-1480 ~ +21920		
Type T		-2000 ~ +4000	Type T	-3280 ~ +7520		
Type R		0 ~ 16000	Type R	320 ~ 29120		
Type S		0 ~ 16000	Type S	320 ~ 29120		
Mini. resolution		Type K	0.3°C	Type K	0.54°F	
		Type J	0.2°C	Type J	0.36°F	
	Type E	0.3°C	Type E	0.54°F		
	Type N	0.3°C	Type N	0.54°F		
	Type T	0.2°C	Type T	0.36°F		
	Type R	0.5°C	Type R	0.9°F		
	Type S	0.5°C	Type S	0.9°F		
Accuracy		±(Full scale 0.5%+1°C), Water condensation point: 0°C/32°F				
Isolation		The analog circuit is isolated from the digital circuit with optocoupler. The analog circuit is isolated from the internal power supply of module input 24VDC. No need to isolate the analog channels.				

Model definition

Name of the main module and I/O extension modules

IVC 1-16 14 MAT 1

Version No.

Output

R: Relay output
T: Transistor output
N: None

Module power

A: AC220V input
D: DC24V input
N: No external power input

Module type

M: Main module
E: Extension module

Output points

Input points

Serial No.

Logo of INVT PLC

Name of the special modules

IVC 1-4 AD

Name

AD: Analog Input Module
DA: Analog output module
PT: Thermal resistance temperature module
TC: Thermocouple module
AM: The analog input and output modules

Channel No.

Serial No.

Logo of INVT PLC

Model

Main module (AC power supply)

Project	Specification	Size (mm) LxWxH
IVC1-1006MAR	10-point 24VDC input, 6-point relay output	135x90x71.2
IVC1-1006MAT	10-point 24VDC input, 6-point transistor output	135x90x71.2
IVC1-1410MAR	14-point 24VDC input, 10-point relay output	135x90x71.2
IVC1-1410MAT	14-point 24VDC input, 10-point transistor output	135x90x71.2
IVC1-1614MAR	16-point 24VDC input, 14-point relay output	150x90x71.2
IVC1-1614MAT	16-point 24VDC input, 14-point transistor output	150x90x71.2
IVC1-1614MAR1	16-point 24VDC input, 14-point relay output, 2-point analog input 1-point analog output	182x90x71.2
IVC1-1614MAT1	16-point 24VDC input, 14-point transistor output, 2-point analog input 1-point analog output	182x90x71.2
IVC1-2416MAR	24-point 24VDC input, 16-point relay output	182x90x71.2
IVC1-2416MAT	24-point 24VDC input, 16-point transistor output	182x90x71.2
IVC1-3624MAR	36-point 24VDC input, 24-point relay output	224.5x90x71.2
IVC1-3624MAT	36-point 24VDC input, 24-point transistor output	224.5x90x71.2

Main module (DC power supply)

Project	Specification	Size (mm) LxWxH
IVC1-1006MDR	10-point 24VDC input, 6-point relay output	135x90x71.2
IVC1-1006MDT	10-point 24VDC input, 6-point transistor output	135x90x71.2
IVC1-1410MDR	14-point 24VDC input, 10-point relay output	135x90x71.2
IVC1-1410MDT	14-point 24VDC input, 10-point transistor output	135x90x71.2
IVC1-1614MDR	16-point 24VDC input, 14-point relay output	150x90x71.2
IVC1-1614MDT	16-point 24VDC input, 14-point transistor output	150x90x71.2
IVC1-2416MDR	24-point 24VDC input, 16-point relay output	182x90x71.2
IVC1-2416MDT	24-point 24VDC input, 16-point transistor output	182x90x71.2
IVC1-3624MDR	36-point 24VDC input, 24-point relay output	224.5x90x71.2
IVC1-3624MDT	36-point 24VDC input, 24-point transistor output	224.5x90x71.2

I/O extension module

Project	Specification	Size (mm) LxWxH
IVC1-0800ENN	8-point 24VDC input	61x90x71.2
IVC1-0008ENR	8-point relay output	
IVC1-0008ENT	8-point transistor output	
IVC1-0016ENR	16-point relay output	
IVC1-0016ENT	16-point transistor output	
IVC1-0808ENR	8-point 24VDC input, 8-point relay output	
IVC1-0808ENT	8-point 24VDC input, 8-point transistor output	

Special function module

Project	Specification	Size (mm) LxWxH
IVC1-2AD	2-point analog input	61x90x71.2
IVC1-2DA	2-point analog output	
IVC1-4AD	4-point analog input	
IVC1-4DA	4-point analog output	
IVC1-5AM	4-point analog input, 1-point analog output	
IVC1-2TC, IVC1-4TC	2, 4-point thermocouple	
IVC1-2PT, IVC1-4PT	2, 4-point thermal resistor	

Communication adapter

Project	Specification	Size (mm) LxWxH
IVCS-EPM	Serial to Ethernet communications	56x82x26

Parts

Project	Specification	Cable length
IVC-SL1	Download cable of the serial port	3m
IVC-SL2	Download cable of USB	2m
IVC-SL3	Connection cable of HMI-PLC	3m
IVC-SL4	Download cable of USB(HMI)	1.5m

- ▶ High-speed u disk accessing
- ▶ Transferring data between PC and HMI using USB cable
- ▶ Supporting all latest softwares



10.4"
800×600 Pixels
64K color

VT104-H1ET-N
VT104-N1CT-N



7"
800×480 Pixels
64K color

VT070-H1ET-N
VT070-H1ET-W
VT070-N0CX-N
VT070-N0CX-W



5.6"
320×234 Pixels
64K color

VT056-H0CT-N
VT056-H0CT-W
VT056-N0CX-N
VT056-N0CX-W

Model definition

VT070-H1ET-N

Hole size : N : Common, W : W type, None : Common

COM2 communication port : X : N, T : Y

Ethernet interface : C : N, E : Y

SD Card slot and flash memory

Degree : H : High-performance, N : Common

Screen size : 104 : 10.4", 070 : 7", 056 : 5.6"

The logo of INVT touch screen

Specifications and technical datas

Specification	Content	VT104-H1ET-N	VT104-N1CT-N	VT070-H1ET-N/W	VT070-N0CX-N/W	VT056-H0CT-N/W	VT056-N0CX-N/W
Display	Dimension	10.4"		7"		5.6"	
	Resolution	800×600		800×480		320×234	
	Display Type	TFT					
	Color	65536-color					
	Backlight service life	20000 hours					
	Brightness	400cd/m ²	300cd/m ²	300cd/m ²	200cd/m ²	200cd/m ²	200cd/m ²
	Touch screen	4-wire resistive touch screen					
	Backlight module	LED					
Hardware resources	Processor	32位RISC SOC Integrated graphics accelerator					
	Processing speed	200 MHZ					
	Memory	64M		64M		32M	
	Battery backup memory	128 KB (optional 1MB)	128 KB (optional 1MB)	128 KB (optional 1MB)	128 KB	128 KB	128 KB
	Flash program memory	8M + 128MB NAND Flash	8M+128MB NAND Flash	8M	8M	8M	8M
Interface	Ethernet port	1 x 10/100Mb	None	1 x 10/100Mb	None	None	None
	USB interface	1 main board , 1 non-main-board					
	Print Interface	None					
	Serial interface	com1:RS232/422/485 com2:RS232/485 com3:RS232		com1:RS232/422/485 com2:RS232/485 com3:RS232		com1:RS232/422/485 com3:RS232	
	Micro SD card slot	Y			N		
Power supply	Input power	24V DC+-10%					
	Power consumption	20W	15W	15W	13W	13W	13W
	Operating temperature	0℃ ~ 50℃					
Environment	Storage Temperature	-20℃~60℃					
	Relative humidity	10%~90% RH (no condensation)					
	Storage humidity	10%~90% RH (no condensation)					
	Protection class	NEMA 4/ IP65 (front panel)					
	Safety certification	CE / FCC					
	Cooling	Natural cooling					
	Structure	Outlet dimension (WxH;mm)	270.1X212.1	N type: 188X143.3 W type: 203.5X148.5	N type: 188 x 143.3 W type: 203.5X148.5	N type: 174.5x132.5 W type: 191.0x137.5	N type: 174.5 x 132.5 W type: 191.0x137.5
Cut out dimension (WxH;mm)	259.0x201.0						
Cut out depth (mm)	42.5	40	40	40	40	40	
Depth of front panle (mm)	6	6	6	6	6	6	
Net weight	1.2 Kg	0.6 Kg	0.6 Kg	0.59 Kg	0.59 Kg	0.59 Kg	

PLC Outlet Dimension

Main module



Main module	W1	W2	W3
16-point main module	135 mm	90 mm	71.2mm
24-point main module	135 mm	90 mm	71.2mm
30-point main module	150mm	90 mm	71.2mm
40-point main module	182mm	90 mm	71.2mm
60-point main module	224.5mm	90 mm	71.2mm
Main module with integrated analog	182 mm	90 mm	71.2mm

Extension Module



All IVC1 extension modules have same dimensions.

- ▶ Analog Input Module
- ▶ Analog output module
- ▶ The analog input and output modules
- ▶ Thermocouple input module
- ▶ RTD temperature input module

Communication adapter



IVCS-EPM

HMI Outlet Dimension

VT104-H1ET-N; VT104-N1CT-N

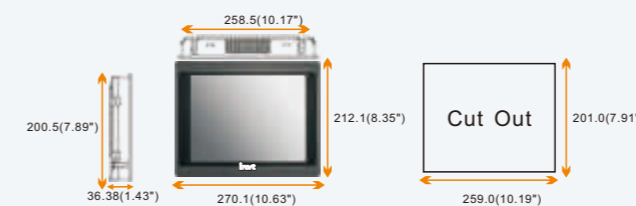

VT070-H1ET-N; VT070-N0CX-N

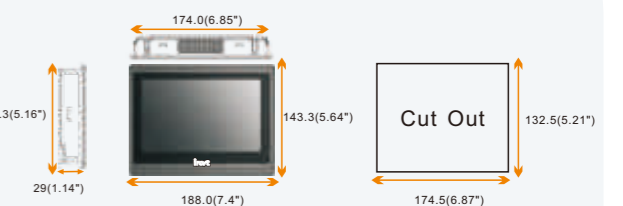

VT056-H0CT-N; VT056-N0CX-N

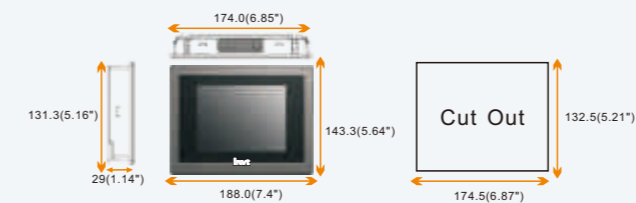

VT070-H1ET-W; VT070-N0CX-W
VT056-H0CT-W; VT056-N0CX-W

